

VESOUL



AMBIANCE



ESTAMPILLE



POINTOISE



VESOUL

versions fixe ou amovible fusible

Acier électrozingué peint.
Tête en fonte métallisée peinte.
Existe en hauteur 1200 mm.

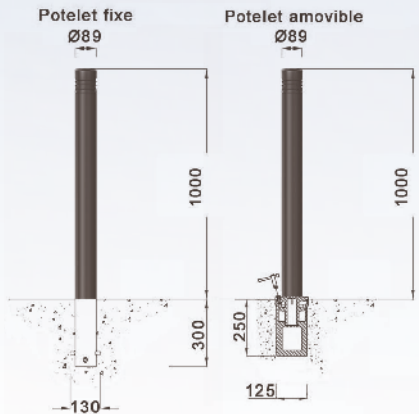

ligne AMBIANCE

versions fixe ou fusible

Corps en acier galvanisé peint et tête en fonte métallisée peinte.
Existe en version escamotable.
Design J.P. Deschamps

Borne fixe

Borne fusible

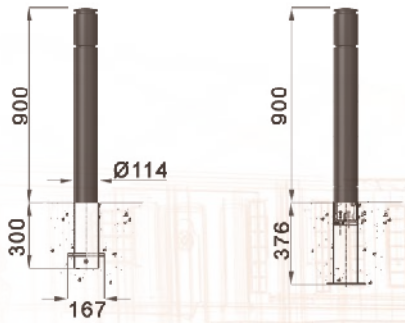

ligne ESTAMPILLE

versions fixe ou amovible fusible

Corps en acier et tête en aluminium peints.
Design R. Dufour

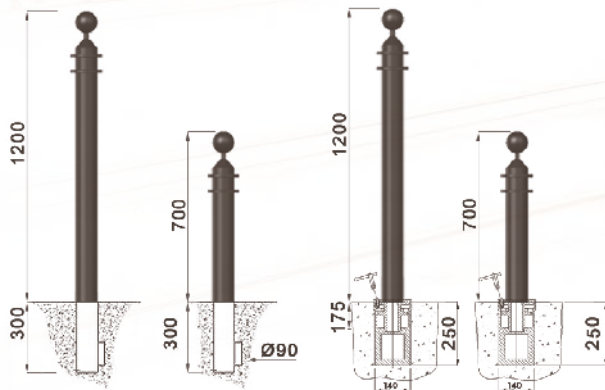

POINTOISE

versions fixe ou amovible-fusible

Fonte métallisée peinte.

Potelet amovible fusible

Potelet fixe

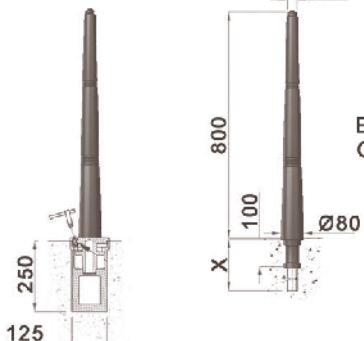

En standard X=300
Options : X=200 ou X=400



ESTAMPILLE 1200

ESTAMPILLE 700



Principe du fusible :

Un fusible calibré (2) est inséré entre le scellement (3) et le potelet (1).
Un remplacement de l'élément fusible simple et rapide diminue de façon sensible les frais de remise en état.





GHM Eclatec BV

Brabantsestraat 16
3074 RS Rotterdam
T 010-4321132
F 010-4324148
E info@ghm-eclatec.nl
I www.ghm-eclatec.nl
IBAN NL93RABO0159582490
BTW NL 850918066B01
Onderdeel van de GHM groep

Stabanken

Boomkorsetten

Banken

Fonteinen

Zuilen

Hekwerk

Led verlichting

Houten lichtmasten

Autonome verlichting

Lichtzuilen

Kiosken

Boomroosters

Plantenbakken

Fietsrekken

Klassieke lichtmasten

Openbare verlichting ***Signalisatie***

Terrein verlichting

Afzetpalen

Standbeelden / Kunst

Auteursrechten en intellectuele eigendomsrechten

Het auteursrecht op deze brochure berust bij GHM Eclatec B.V. of bij derden (GHM SA en Eclatec SAS) welke met toestemming dit (beeld)materiaal beschikbaar hebben gesteld aan GHM Eclatec B.V. Vermenigvuldiging in wat voor vorm dan ook is alleen toegestaan na voorafgaande toestemming door GHM Eclatec B.V. Copyright © 2013 GHM Eclatec B.V. Foto credits: ©Eclatec, ©Fotolia, ©Shutterstock. Alle rechten voorbehouden